

# POOL COPING

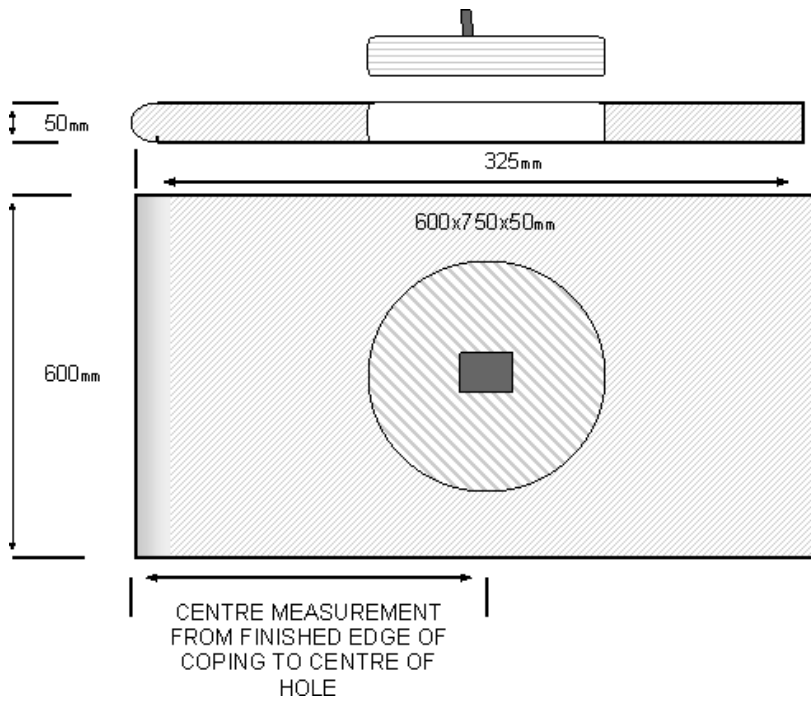

bnSKIMMERBOX

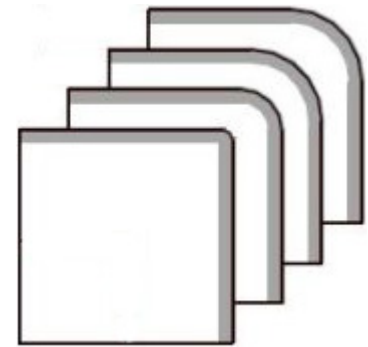

EXTERNAL BULLNOSE

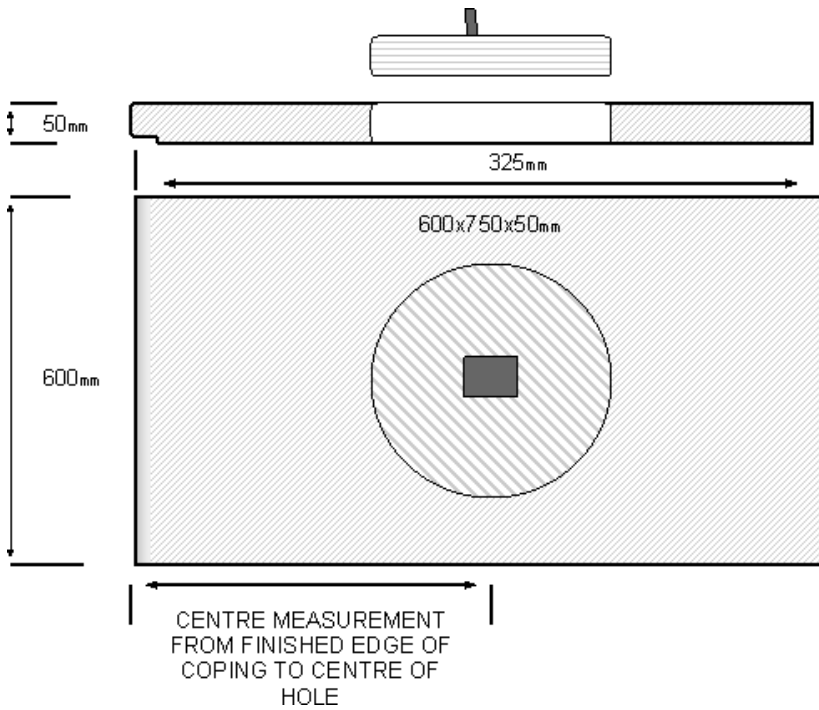

SECSKIMMERBOX

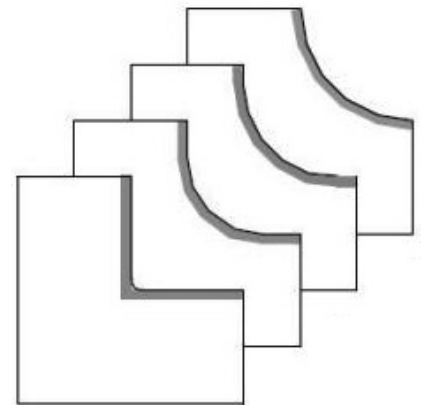

INTERNAL CRNS

# Cast Bullnose Coping

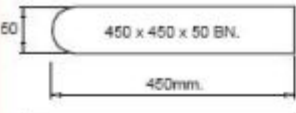
Bullnose Profile.		STANDARD SIZES.	UNITS PER PALLET	APPROX WEIGHT
	450x450x50	450x450x50mm	60	18kg ea.
		450x350x50mm	60	12kg ea.
		600x300x50mm	60	15kg ea.
		600x350x50mm	60	17kg ea.
		600x450x50mm*	45	20kg ea.
		600x600x50mm*	25	28kg ea.
		*Additional production time req.		

**INTERNAL BULLNOSE CORNERS.**  
All corners made to suit coping width  
Standard sizes  
300mm deep coping  
350mm deep coping  
450mm deep coping  
600mm deep coping\*  
\*Sharp and R=175mm corners only.

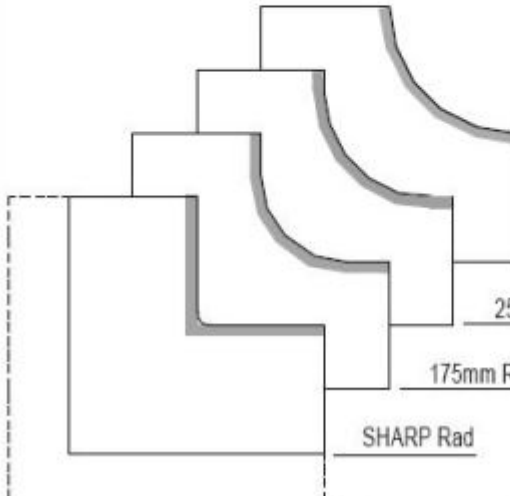

300mm Rad  
250mm Rad  
175mm Rad  
SHARP Rad

All Corners are made Larger & are to be cut down on site.

**EXTERNAL BULLNOSE CORNERS**  
450x450x50mm  
600x600x50mm

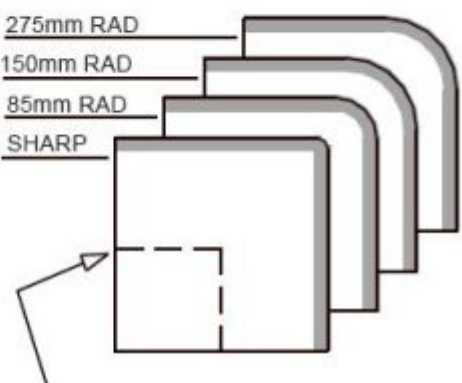

275mm RAD  
150mm RAD  
85mm RAD  
SHARP

All External Bullnose Corners are made 450x450x50mm or 600x600x50mm and require their back corner to be cut down to suit coping width.

**INTERNAL BULLNOSE CURVES**  
All curves are approx; 600mm long and come either 350mm or 450mm deep.



Internal Curve Radii  
400mm, 850mm, 1100mm, 1450mm, 1700mm, 2000mm, 2200mm, 2600mm, and 3000mm.

**EXTERNAL BULLNOSE CURVES**  
All curves are approx; 600mm long and come either 350mm or 450mm deep.

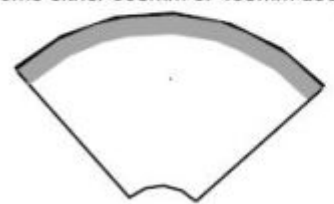

External Curve Radii  
650mm, 950mm, 1250mm, 1550mm, 1700mm, 2150mm, 2400mm, 2600mm, and 3800mm.

**135deg BULLNOSE CORNERS.**  
All corners come 450mm deep and require the back edge to be cut back to suit coping width.

Internal 135° Angled Corner

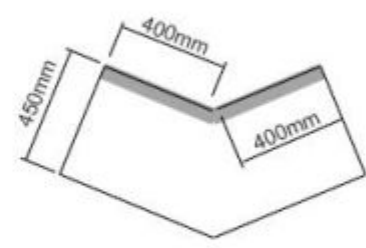

400mm  
400mm  
450mm

External 135° Angled Corner

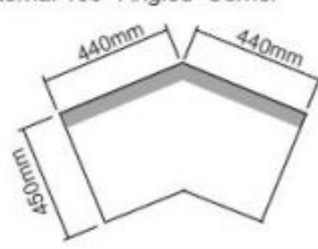

440mm  
440mm  
450mm

**BULLNOSE SKIMMER BOXES & SKIMMER LIDS**

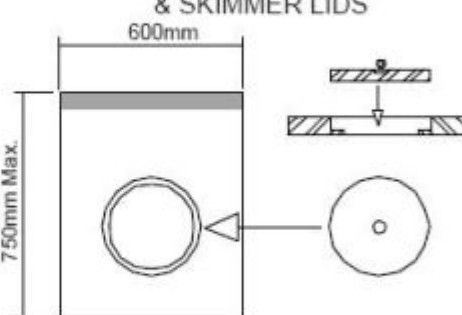

600mm  
750mm Max.

All lids have stainless steel ring pull handle. Position of hole can be measured off pool shell and skimmer box is made to suit. Alternatively a 600x600x50mm skimmer box without a bullnose edge can be used.

Standard sizes.  
Skimmer Lid (320mm Dia. x 40mm)  
600x750x50mm Bullnose Skimmer box  
600x600x50mm Skimmer box

# Dual Bull Nose Coping

<p><b>Bullnose Profile.</b></p>	<p><b>STANDARD SIZES.</b></p> <p>145Wx600Lx50mm 180Wx600Lx50mm 210Wx600Lx50mm 255Wx600Lx50mm 280Wx600Lx50mm 325Wx600Lx50mm 380Wx600Lx50mm.</p>	<p><b>DUAL BN RETURNS STANDARD SIZES.</b></p> <p>145Wx400Lx50mm 180Wx400Lx50mm 210Wx400Lx50mm 255Wx400Lx50mm 280Wx400Lx50mm 325Wx400Lx50mm 380Wx400Lx50mm.</p>	
---------------------------------	--	--	--

\*Additional production time required - All Dual Bullnose can be made 60mm thick.

<p><b>DUAL BULLNOSE CORNERS</b></p> <p><b>DUAL BN CORNERS STANDARD SIZES.</b></p> <p>180Wx400Lx50mm 210Wx400Lx50mm 255Wx400Lx50mm 280Wx400Lx50mm 325Wx400Lx50mm</p> <p>*Not all dual bullnose sizes have corners to suit therefore you need to mitre cut corners on site.</p>	<p><b>SPECIALIST DUAL BULLNOSE SPA PRODUCTS</b></p> <div style="display: flex; justify-content: space-around;"> <div data-bbox="798 649 1037 963"> <p>#1 Spa Connector. 280mm</p> </div> <div data-bbox="1037 649 1276 963"> <p>#2 Spa Connector. 255mm</p> <p>175 Radius.</p> </div> <div data-bbox="1276 649 1548 963"> <p>Skimmer box Surround. 450mm</p> </div> </div>
---	--

## BULLNOSE POOL COPING LAYOUT

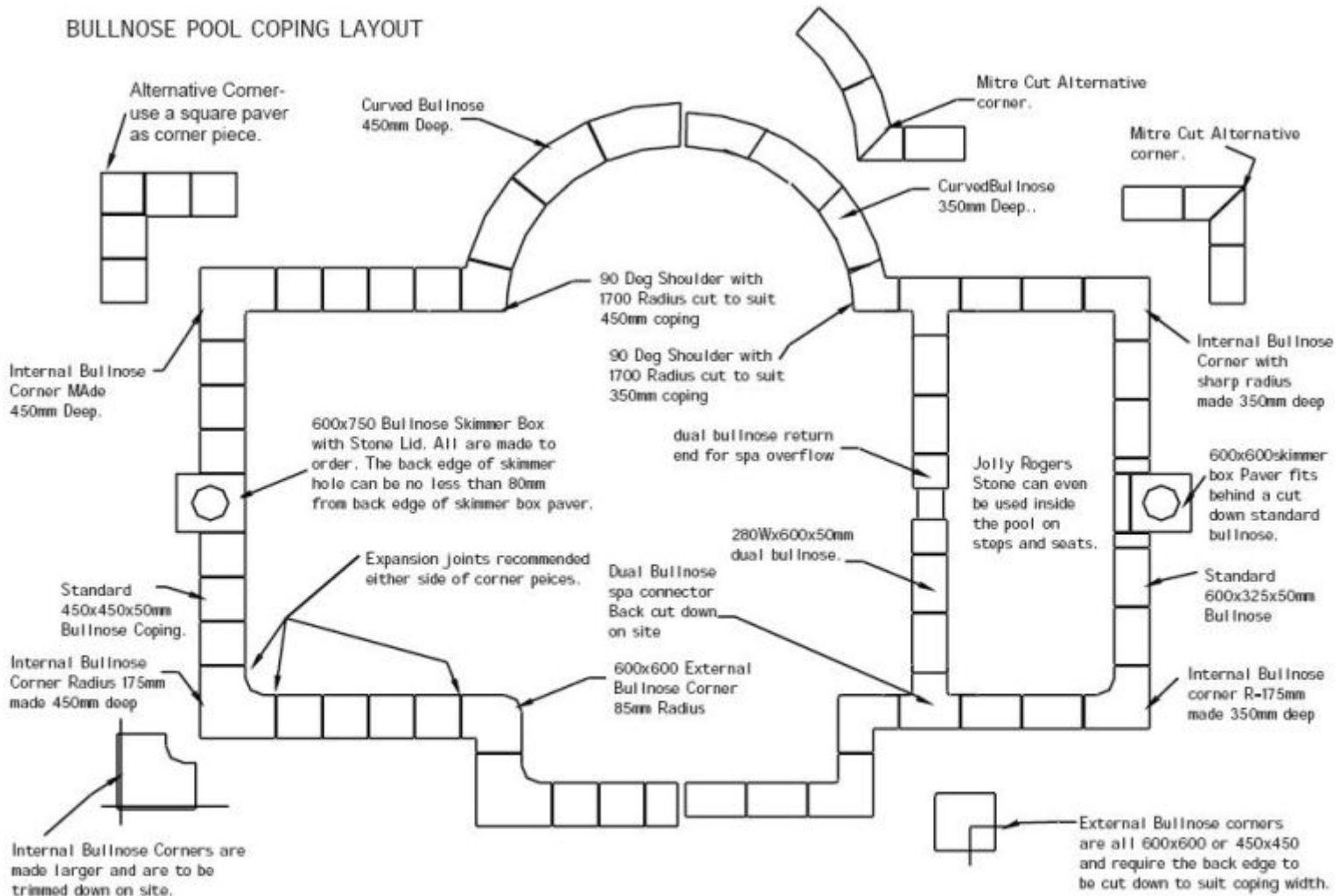

# Square Edge Coping

## SQUARE EDGE COPING PROFILE.

	STANDARD SIZES.	UNITS PER PALLET	APPROX WEIGHT
	450x450x50mm 450x350x50mm 600x325x50mm 600x350x50mm* 600x450x50mm* 600x625x50mm* *Additional production time req. All moulds can be reduced in width to suit coping sizes not listed above.	60 60 60 60 45 25	18kg ea. 12kg ea. 15kg ea. 17kg ea. 20kg ea. 28kg ea.

**SQUARE EDGE INTERNAL CORNERS.**

All Corners are made Larger & are to be cut down on site.

All corners made to suit coping width

Standard sizes      Price each

325mm deep coping  
450mm deep coping

**SQUARE EDGE EXTERNAL CORNERS**  
450x450x50mm  
625x600x50mm

All External Corners are made 450x450x50mm or 600x600x50mm and require their back corner to be cut down to suit coping width.

**SQUARE EDGE SKIMMER BOXES & SKIMMER LIDS**

600mm  
625 mm Max.

All lids have stainless steel ring pull handle. Position of hole can be measured off pool shell and skimmer box is made to suit. Alternatively a 600x600x50mm skimmer box without a bullnose edge can be used.

**DUAL SQUARE EDGE COPING**  
600 x 250 x 50mm  
One end of this piece comes with a return BN.

Standard sizes.  
Skimmer Lid (320mm Dia. x 40mm)  
600x625x50mm BN Skimmer box  
600x600x50mm Skimmer box

**SQUARE EDGE POOL COPING LAYOUT**

Internal sq/edged coping Corner MAde 450mm Deep.

Standard 450x450x50mm Square edge Coping.

600x250x50mm Dual sq/ edge with return end for spa overflow.

600x600 External Sq/ Edge Corner

Alternative Corner - use a square paver as corner piece.

Standard 600x325x50mm Square Edged coping

Mitre Cut Alternative corner.

External sq/edged coping corners are all 600x600 or 450x450 and require the back edge to be cut down to suit coping width.

600x625 sq/edged coping Skimmer Box with Stone Lid. All are made to order. The back edge of skimmer hole can be no less than 80mm from back edge of skimmer box paver.

Internal sq/edged Corners are made larger and are to be trimmed down on site.